

Determination of the Specific Charge of the Electron

Objects of the experiment

- Study of the deflection of electrons in a magnetic field into a circular orbit.
- Determination of the magnetic field B as a function of the acceleration potential U of the electrons at a constant radius r .
- Determination of the specific charge of the electron.

Principles

The mass m_e of the electron is hard to come by experimentally. It is easier to determine the specific charge of the electron

$$\varepsilon = \frac{e}{m_e} \quad (\text{I}),$$

from which the mass m_e can be calculated if the elementary charge e is known:

An electron moving at velocity v perpendicularly to a homogenous magnetic field B , is subject to the Lorentz force

$$F = e \cdot v \cdot B \quad (\text{II})$$

which is perpendicular to the velocity and to the magnetic field. As a centripetal force

$$F = m_e \cdot \frac{v^2}{r} \quad (\text{III})$$

it forces the electron into an orbit of radius r (see Fig. 1), thus

$$\frac{e}{m_e} = \frac{v}{r \cdot B} \quad (\text{IV})$$

In the experiment, the electrons are accelerated in a fine beam tube by the potential U . The resulting kinetic energy is

$$e \cdot U = \frac{m_e}{2} \cdot v^2 \quad (\text{V})$$

The specific charge of the electron thus is

$$\frac{e}{m_e} = \frac{2 \cdot U}{(r \cdot B)^2} \quad (\text{VI}).$$

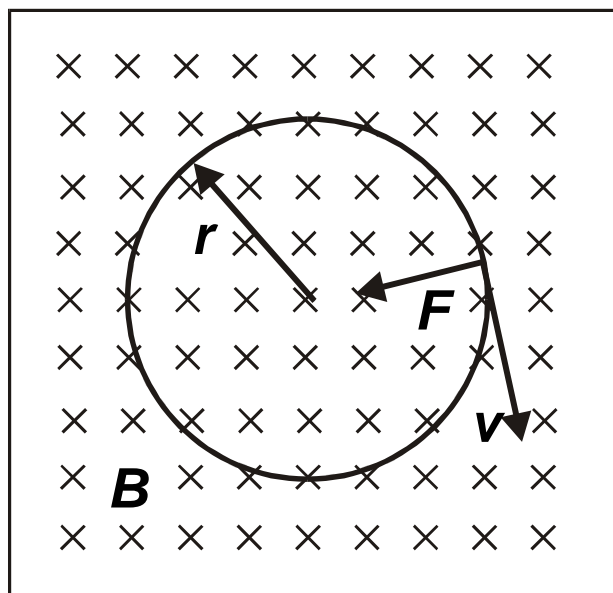

Fig. 1: Deflection of electrons in a magnetic field B by the Lorentz force F into a circular orbit of a given radius r .

Apparatus

| | |
|---|---------|
| 1 Fine beam tube..... | 555 571 |
| 1 Helmholtz coils with holder and measuring device | 555 581 |
| 1 Tube power supply 0 to 500 V | 521 65 |
| 1 DC Power Supply 0...16 V, 0...5 A | 521 545 |
| 2 Multimeter LD analog 20..... | 531 120 |
| 1 Steel tape measure, l = 2 m/78" | 311 77 |
| 3 Safety connecting leads, 25 cm..... | 500 614 |
| 3 Safety connecting leads, 50 cm..... | 500 624 |
| 7 Safety connecting leads, 100 cm..... | 500 644 |

Additionally recommended:

| | |
|---|----------|
| 1 Universal Measuring Instrument Physics..... | 531 835 |
| 1 Axial B-Sensor S..... | 524 0382 |
| 1 Extension cable, 15-pole | 501 11 |

The fine beam tube contains hydrogen molecules at low pressure, which through collisions with electrons are caused to emit light. This makes the orbit of the electrons indirectly visible, and their orbiting radius r can be directly measured with a ruler.

The magnetic field B is generated in a pair of Helmholtz coils and is proportional to the current I in the Helmholtz coils:

$$B = k \cdot I \quad (\text{VII})$$

The dependence on the accelerating potential U of the current I , in the magnetic field of which the orbiting radius of the electrons is kept to a constant value r , follows after recasting equations (VI) and (VII)

$$U = \frac{e}{m_e} \cdot \frac{1}{2} \cdot r^2 \cdot k^2 \cdot I^2 \quad (\text{VIII})$$

The proportionality factor

$$k = \mu_0 \cdot \left(\frac{4}{5}\right)^{\frac{3}{2}} \cdot \frac{n}{R} \quad (\text{IX})$$

$$\mu_0 = 4\pi \cdot 10^{-7} \frac{\text{Vs}}{\text{Am}} : \text{magnetic field constant}$$

can be calculated either from the coil radius $R = 150$ mm and the winding factor $n = 130$ per coil, or be determined by recording a calibration curve $B = f(I)$. All determining factors for the specific electron charge are now known.

Safety notes

The Attention: The fine beam tube requires dangerous contact voltages up to 300 V for accelerating the electrons. Other voltages that are connected with this dangerous contact voltage also present a contact hazard. Dangerous contact voltages are thus present at the connection panel of the holder and at the Helmholtz coils when the fine beam tube is in operation.

- Connect the connection panel only via safety connecting leads.
- Always be sure to switch off all power supplies before connecting and altering the experiment setup.
- Do not switch on the power supplies until you have finished assembling the circuit.
- Do not touch the experiment setup, particularly the Helmholtz coils, during operation.

Danger of implosions: The fine beam tube is a evacuated glass vessel with thin walls.

- Do not subject the fine beam tube to mechanical stresses.
- Operate the fine beam tube only in the holder (555 581).
- Connect the 6-pole plug of the holder carefully to the glass base.
- Read the instruction sheet supplied with the fine beam tube.

Setup

Note:

Perform measurements in a dark chamber.

Helmholtz coils may be charged with more than 2 A for short time only.

The experimental setup to determine the specific electron charge is shown in Fig. 2, the electric connections in Fig. 3.

- Disconnect the tube power supply and turn all rotary potentiometers to left catch position.
- Connect the 6.3-V input end of the fine beam tube to the 6.3-V outlet of the tube power supply.
- Short-circuit the positive pole of the 50-V outlet of the tube power supply with the negative pole of the 500-V outlet and connect with the socket “-” of the fine beam tube (cathode).
- Connect the socket “+” of the fine beam tube (anode) with the positive pole of the 500-V outlet, the socket W (Wehnelt-cylinder) with the negative pole of the 50-V outlet.
- In order to measure the acceleration potential U connect the voltmeter (measuring range 300 V₋) to the 500-V outlet.
- Short the deflection plates of the fine beam tube to the anode.
- Connect the DC power supply and ammeter (measuring range 3 A₋) in series with the Helmholtz coils.

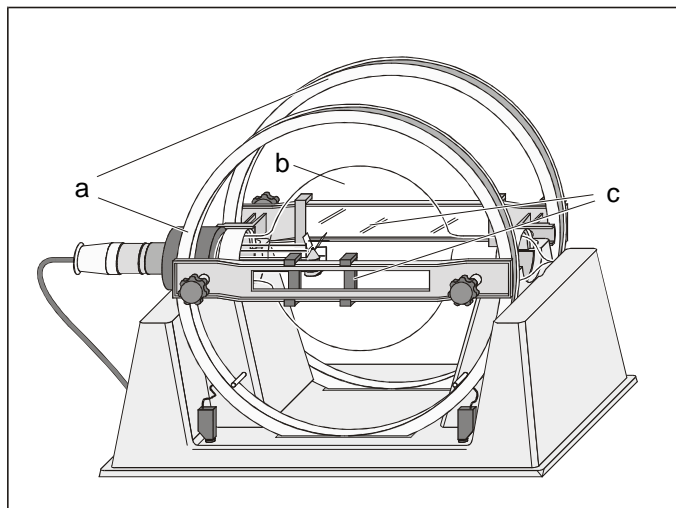
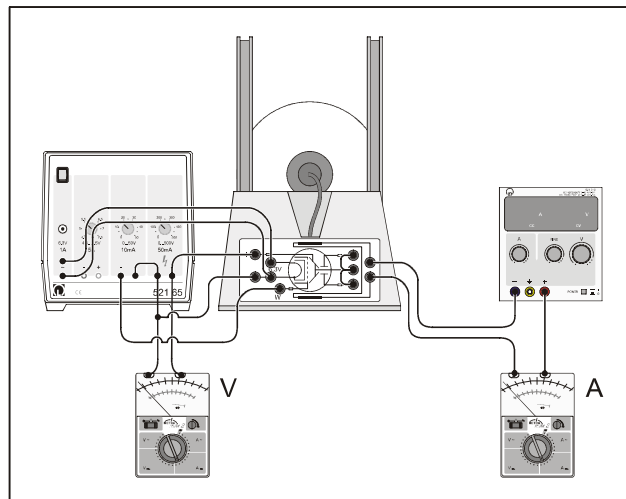

Fig. 2 Experiment setup for determining the specific electron charge

- a** Helmholtz coils
- b** Fine beam tubes
- c** Measuring device

Fig. 3 Electric connection



Carrying out the experiment

- Move the left slide of the measuring device so that its inner edge, mirror image and escape aperture of the electron beam come to lay on one line of sight.
 - Set the right slide for both inside edges to have a distance of 8 cm.
 - Sight the inside edge of the right slide, align it with its mirror image and adjust the coil current I until the electron beam runs tangentially along the slide edge covering the mirror image (see Fig. 4).
 - Reduce the acceleration potential U in steps of 10 V to 200 V and choose the coil current I so that the orbit of the electron beam has a diameter of 8 cm.
 - Record acceleration potential U and coil current I .
- Power up the tube power supply and set acceleration potential $U = 300$ V.
- Thermionic emission starts after warming up for a few minutes.
- Optimize focussing of the electron beam by varying the voltage at the Wehnelt-cylinder from 0...10 V until it leads to a narrow, well defined beam with clear edge definition.
 - Connect the DC power supply of the Helmholtz coils and look for current I , at which the electron beam is deflected into a closed orbit.

If the electron beam after leaving the anode is deflected to the wrong (left) side:

- disconnect both power supplies.
- exchange the connections at the DC power supply in order to change the polarization of the magnetic field.

If the electrons do not move on a closed orbit but on a helical curve line:

- Loosen the mounting bolts of both holding brackets (read the information manual for the fine beam tube).
- Carefully rotate the fine beam tube around its longitudinal axis, until the electron beam runs on a closed circular orbit.
- Fasten mounting bolts.

Fig. 4 Measurement of the orbit diameter with the measuring device

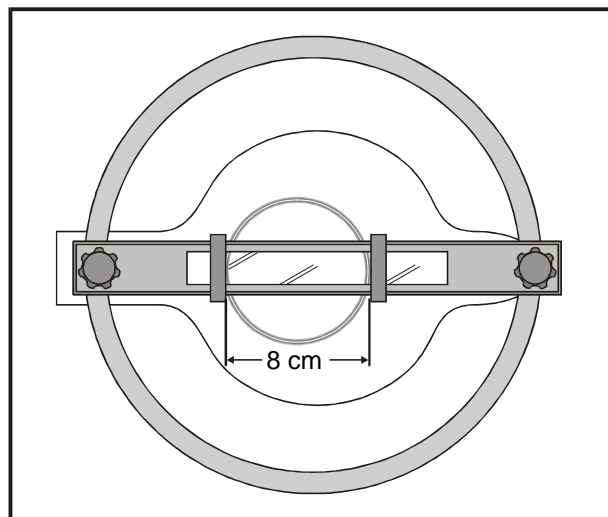

Calibration of the Helmholtz magnetic field (optional):

The setup for calibrating the magnetic field is shown in Fig. 5. The additionally recommended devices mentioned above are required for making measurements.

- If applicable disconnect all power supply units.
- Remove the measuring device and the Helmholtz coil at the front side, loosen the connection to the fine beam tube and the mounting bolts of the two holding brackets (read the instructions for the fine beam tube).
- Carefully remove the fine beam tube and place it e.g. in its original case.
- Re-assemble the Helmholtz at the front side coil and connect.
- Connect the axial B-probe to the Teslameter (measuring range 20 mT) and calibrate the zero-point (see Instruction Manual for Teslameter).
- Move the axial B-probe parallel to the magnetic field of the Helmholtz coils into the center of the pair of coils.
- Raise the coil current I from 0 to 3 A in steps of 0.5 A, measure the magnetic field B , and record the measured values.

After conclusion of the calibration:

- Reassemble the fine beam tube according to the instructions.

Measuring example

Table 1: The Coil current I as a function of the acceleration potential U at constant orbit radius $r = 0,04$ m.

| $\frac{U}{V}$ | $\frac{I}{A}$ |
|---------------|---------------|
| 300 | 2.15 |
| 290 | 2.10 |
| 280 | 2.07 |
| 270 | 2.03 |
| 260 | 2.00 |
| 250 | 1.97 |
| 240 | 1.91 |
| 230 | 1.88 |
| 220 | 1.83 |
| 210 | 1.79 |
| 200 | 1.75 |

Table 2: The Magnetic field B of the Helmholtz coils as a function of the coil current I (this measurement requires the above mentioned additionally recommended devices)

| $\frac{I}{A}$ | $\frac{B}{mT}$ |
|---------------|----------------|
| 0.5 | 0.35 |
| 1.0 | 0.65 |
| 1.5 | 0.98 |
| 2.0 | 1.34 |
| 2.5 | 1.62 |
| 3.0 | 2.05 |

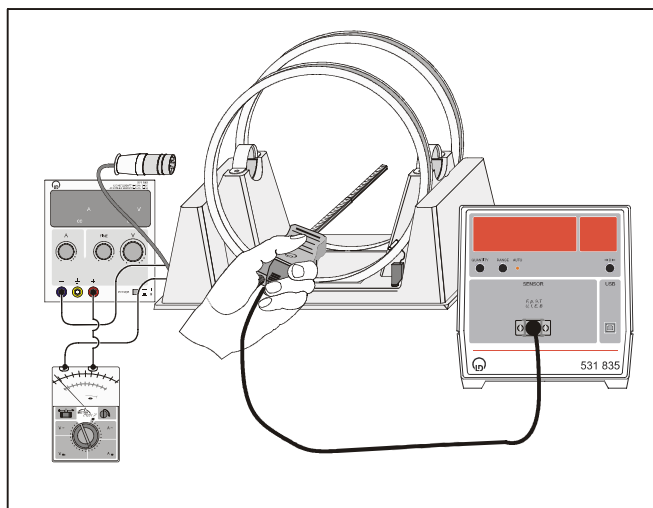

Fig. 5 Set-up for calibration of the Helmholtz magnetic field

Evaluation and results

In Fig. 6 the measured values from Tab. 1 are shown in their linear form $U = f(I^2)$ – according to (VIII). The slope of the resulting line through the origin is

$$\alpha = 65,3 \text{ V A}^{-2}.$$

According to equation (VIII), the specific electron charge is

$$\frac{e}{m_e} = \frac{2 \cdot \alpha}{r^2 \cdot k^2}$$

Further evaluation thus requires the proportionality factor k .

If the light bundles impinge perpendicularly ($\alpha = \beta$) they are reflected back onto themselves.

If the light bundles impinge obliquely they are reflected into other directions, but remain parallel.

Fig. 6 Presentation of the measuring results from Table 1

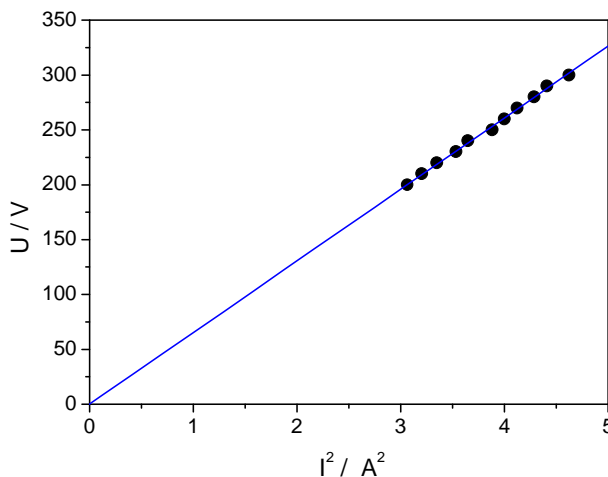

Determination of the proportionality factor k from the calibration of the Helmholtz magnetic field:

Fitting of a straight line through the origin to the measuring values of Tab. 2, or of Fig. 7 leads to

$$k = 0,67 \text{ mT A}^{-1}$$

and further

$$\frac{e}{m_e} = 1,8 \cdot 10^{11} \frac{\text{As}}{\text{kg}}$$

Calculation of the proportionality factor k:

Using (IX) one calculates

$$k = 0,78 \text{ mT A}^{-1}$$

and further

$$\frac{e}{m_e} = 1,3 \cdot 10^{11} \frac{\text{As}}{\text{kg}}$$

Documented value:

$$\frac{e}{m_e} = 1,76 \cdot 10^{11} \frac{\text{As}}{\text{kg}}$$

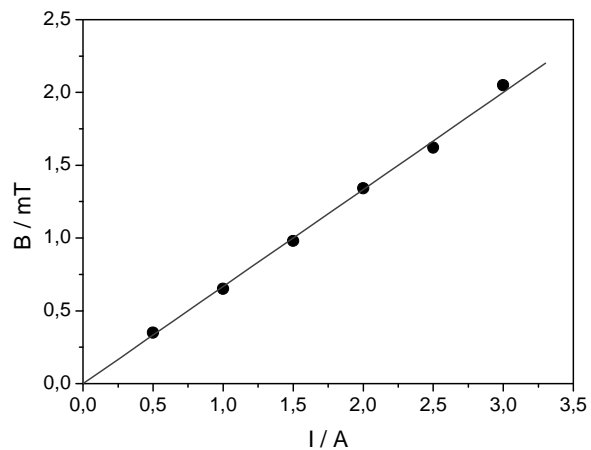

Fig. 7 Calibration curve for the magnetic field of the Helmholtz coils