

Edge absorption: filtering x-rays

Objects of the experiment

- Recording the unfiltered spectrum of an x-ray tube and the spectrum filtered using as zirconium foil.
- Comparing the intensities of the characteristic lines in the filtered and unfiltered spectrum.

Principles

When x-rays pass through matter, they are attenuated by absorption and scattering of the x-ray quanta; the absorption effect often predominates. This is due essentially to ionization of atoms, which release an electron from an inner shell, e.g. the K-shell. This can only occur when the quantum energy

$$E = \frac{h \cdot c}{\lambda} \quad (I)$$

h : Planck's constant,
 c : velocity of light

is greater than the binding energy E_K of the shell. The transmission

$$T = \frac{R}{R_0} \quad (II)$$

R : intensity behind attenuator
 R_0 : intensity in front of attenuator

of the material thus increases abruptly as a function of the wavelength at

$$\lambda_K = \frac{h \cdot c}{E_K} \quad (III)$$

This abrupt change is known as the absorption edge, here the K-absorption edge.

We must distinguish between the K-absorption edge and the characteristic x-radiation K_α and K_β emitted by the excited atoms on the transition of an electron from a higher shell to the K-shell (see experiments P6.3.3.1 and P6.3.3.4). The relationship

$$\lambda(K_\alpha) = \frac{h \cdot c}{E_K - E_L} \text{ and } \lambda(K_\beta) = \frac{h \cdot c}{E_K - E_M} \quad (IV)$$

applies; thus λ_K is shorter than $\lambda(K_\alpha)$ and $\lambda(K_\beta)$. All three quantities depend on the atomic number Z of the absorbing (and emitting) atoms.

Table 1: Wavelengths $\lambda(K_\alpha)$, $\lambda(K_\beta)$ and λ_K for atomic numbers $Z = 40-42$.

Element	Z	$\frac{\lambda(K_\alpha)}{\text{pm}}$	$\frac{\lambda(K_\beta)}{\text{pm}}$	$\frac{\lambda_K}{\text{pm}}$
Zr	40	78.74	70.05	68.88
Nb	41	74.77	66.43	65.31
Mo	42	71.08	63.09	61.99

Fig. 1 Principle diagram of the transmission of an attenuator as a function of the x-ray wavelength

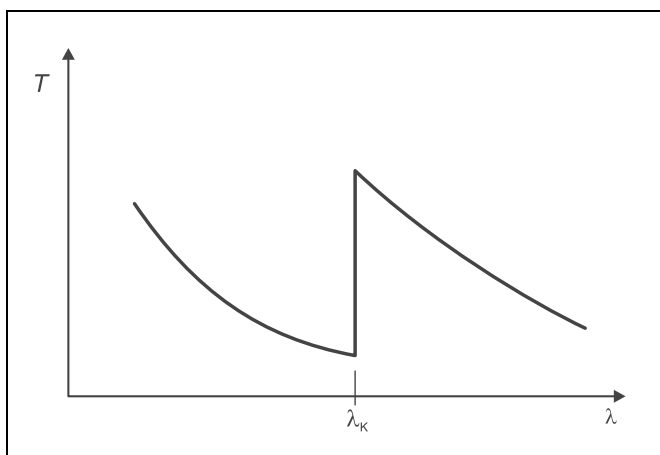

Table 1 contains an excerpt of the relevant literature data [1]. The wavelength of the K_β radiation of molybdenum is below the K-absorption edge λ_K of zirconium, and that of the K_α radiation is just above it. Mo- K_α radiation is thus only slightly attenuated in a zirconium foil, while Mo- K_β radiation is extensively absorbed. With the aid of zirconium foils, the characteristic x-radiation of an Mo anode can be filtered so that an approximately monochromatic beam is obtained behind the foil.

Apparatus

1 X-ray apparatus 554 811

1 End-window counter
for α , β , γ and x-ray radiation 559 01*additionally required:*

1 PC with Windows 9x/NT

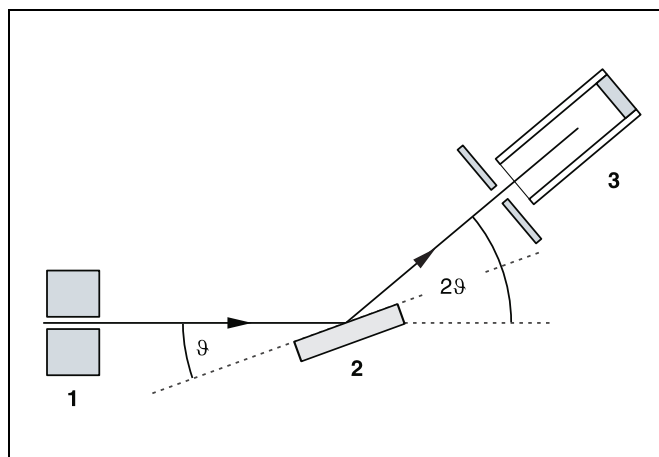

Fig. 2 Schematic diagram of diffraction of x-rays at a monocrystal and 2ϑ coupling between counter-tube angle and scattering angle (glancing angle)
1 collimator, 2 monocrystal, 3 counter tube

This experiment measures the spectrum of an x-ray tube with Mo anode, both unfiltered and filtered, using a zirconium foil. A goniometer with NaCl crystal and a Geiger-Müller counter tube in the Bragg configuration are used to record the intensities as a function of the wavelength. The crystal and counter tube are pivoted with respect to the incident x-ray beam in 2ϑ coupling, i.e. the counter tube is turned at an angle twice as large as the crystal (see Fig. 2).

In accordance with Bragg's law of reflection, the scattering angle ϑ in the first order of diffraction corresponds to the wavelength

$$\lambda = 2 \cdot d \cdot \sin \vartheta \quad (V)$$

$d = 282.01 \text{ pm}$: lattice plane spacing of NaCl

Safety notes

The x-ray apparatus fulfills all regulations governing an x-ray apparatus and fully protected device for instructional use and is type approved for school use in Germany (NW 807/97 Rö).

The built-in protection and screening measures reduce the local dose rate outside of the x-ray apparatus to less than $1 \mu\text{Sv/h}$, a value which is on the order of magnitude of the natural background radiation.

- Before putting the x-ray apparatus into operation inspect it for damage and to make sure that the high voltage is shut off when the sliding doors are opened (see Instruction Sheet for x-ray apparatus).
- Keep the x-ray apparatus secure from access by unauthorized persons.

Do not allow the anode of the x-ray tube Mo to overheat.

- When switching on the x-ray apparatus, check to make sure that the ventilator in the tube chamber is turning.

The goniometer is positioned solely by electric stepper motors.

- Do not block the target arm and sensor arm of the goniometer and do not use force to move them.

Setup**Setup in Bragg configuration:**

Set up the experiment as shown in Fig. 3. To set up the experiment, proceed as follows (see also the Instruction Sheet for the x-ray apparatus):

- Mount the collimator in the collimator mount (a) (note the guide groove).
- Attach the goniometer to guide rods (d) so that the distance s_1 between the slit diaphragm of the collimator and the target arm is approx. 5 cm. Connect ribbon cable (c) for controlling the goniometer.
- Remove the protective cap of the end-window counter, place the end-window counter in sensor seat (e) and connect the counter tube cable to the socket marked GM TUBE.
- By moving the sensor holder (b), set the distance s_2 between the target arm and the slit diaphragm of the sensor seat to approx. 5 cm.
- Mount the target holder with target stage.
- Loosen knurled screw (g), place the NaCl crystal flat on the target stage (f), carefully raise the target stage with crystal all the way to the stop and carefully tighten the knurled screw (prevent skewing of the crystal by applying a slight pressure).
- If necessary, adjust the mechanical zero position of the goniometer (see Instruction Sheet for x-ray apparatus).

Notes:

NaCl crystals are hygroscopic and extremely fragile.

Store the crystals in a dry place; avoid mechanical stresses on the crystal; handle the crystal by the short faces only.

If the counting rate is too low, you can reduce the distance s_2 between the target and the sensor somewhat. However, the distance should not be too small, as otherwise the angular resolution of the goniometer is no longer sufficient to separate the characteristic K_α and K_β lines.

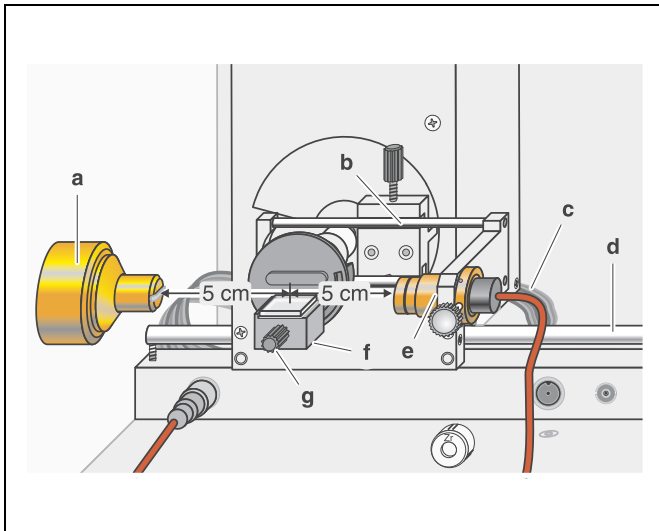

Fig. 3 Experiment setup for investigating the filtration of x-rays

Carrying out the experiment

- Start the software "X-ray Apparatus", check to make sure that the apparatus is connected correctly, and clear any existing measurement data using the button or the F4 key.
- Set the tube high voltage $U = 30.0$ kV, the emission current $I = 1.00$ mA and the angular step width $\Delta\beta = 0.1^\circ$.
- Press the COUPLED key to activate 2θ coupling of target and sensor and set the lower limit of the target angle to 4.2° and the upper limit to 8.3° .
- Set the measuring time per angular step to $\Delta t = 5$ s.
- Start measurement and data transfer to the PC by pressing the SCAN key.
- When the scan is finished, mount the zirconium foil supplied with your x-ray apparatus on sensor seat (e) of the goniometer and start a new measurement by pressing the SCAN key.
- When you have finished measuring, save the measurement series under an appropriate name by pressing the button or the F2 key.
- To display the measurement data as a function of the wavelength λ , open the "Settings" dialog with the button or F5, and in the tab "Crystal", click on the button "Enter NaCl".

Preparing the PC-based measurement:

- Connect the RS-232 output and the serial interface on your PC (usually COM1 or COM2) using the 9-pin V.24 cable (supplied with x-ray apparatus).
- If necessary, install the software "X-ray Apparatus" under Windows 9x/NT (see Instruction Sheet for x-ray apparatus) and select the desired language.

Measuring example

(see Fig. 4)

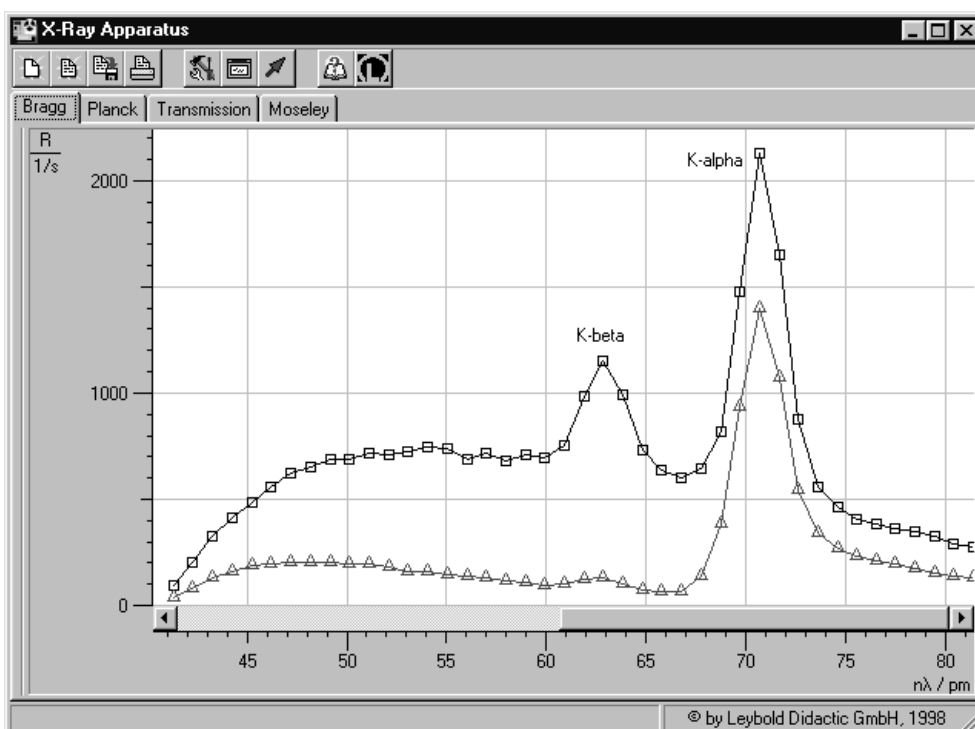

Fig. 4 Diffraction spectrum of x-rays with the characteristic lines of the molybdenum anode in the wavelength range between 40 and 80 pm ($U = 30$ kV) Squares: not attenuated Triangles: attenuated with zirconium foil

Evaluation

- In the diagram, click the right mouse button to access the evaluation functions of the software “X-ray Apparatus” and select the command “Calculate Integral”.
- Using the left mouse button, mark the peaks of the characteristic lines one after another and read their integral counting rate R_i in the bottom left corner of the diagram window.
- Calculate the ratio V of the K_β -radiation to the total characteristic radiation.

$$V = \frac{R_i(K_\beta)}{R_i(K_\alpha) + R_i(K_\beta)}$$

Table 2: Integral counting rates of the characteristic lines and respective proportion of K_β -line.

	$\frac{R_i(K_\alpha)}{s^{-1}}$	$\frac{R_i(K_\beta)}{s^{-1}}$	V
without Zr-Filter	4586	1288	0.22
with Zr-Filter	3897	137	0.034

Results

The proportion of K_β radiation making up the characteristic radiation of the Mo anode is significantly reduced when the zirconium foil is used. This means that:

The characteristic radiation of the Mo anode is approximately monochromatized through absorption in a zirconium foil.

Literature

- [1] C. M. Lederer and V. S. Shirley, Table of Isotopes, 7th Edition, 1978, John Wiley & Sons, Inc., New York, USA.