

Investigation of the characteristic spectra as a function of the element's atomic number: K-lines

Objects of the experiment

- Demonstration of x-ray fluorescence.
- Recording of x-ray fluorescence spectra of several elements and proving of Moseley's law for the *K*-lines of the characteristic spectrum.
- Determination of the atomic screening constant for the electrons in the *K*-shells.

Principle

When operating the x-ray tube, in addition to the continuous bremsstrahlung, the characteristic radiation is also emitted (see also e.g. Physics Leaflet P6.3.3.2). In contrast to the bremsstrahlung, the characteristic radiation does not possess a continuous distribution of radiation intensity in the spectrum – its spectrum is composed of sharp lines.

The characteristic radiation is generated when the electrons which are accelerated towards the anode in the x-ray tube, knock other electrons out of the inner shells of the atoms making up the anode material. The atom ionised in this way then has a vacancy (electron hole) in a lower shell which previously had been full. These electron holes can be filled with electrons from other, weaker bound shells of the atom: e.g. the *K*-shell can be closed by the transition of an electron from the *L*-shell. Such a transition is connected with the emission of a photon. This radiation has only particular discrete photon energies corresponding to the energy difference of the levels involved, and it is characteristic for every chemical element.

The designations of the characteristic x-ray lines are a combination of the symbol for the electron shell (*K*, *L*, *M* etc.) and a Greek letter (α , β , γ etc.). The electron shell being referred to is the one which was ionised before the electron transition. For example the designation $K\alpha$ -line describes the transition from the *L*-shell into the *K*-shell, $K\beta$ refers to the transition from the *M*-shell to the *K*-shell. The $L\alpha$ - and $L\beta$ -lines refer to the transitions from the *M*-shell and the *N*-shell to the *L*-shell.

If viewed more closely, it becomes apparent that the historically developed nomenclature of the x-ray lines is not always logical.

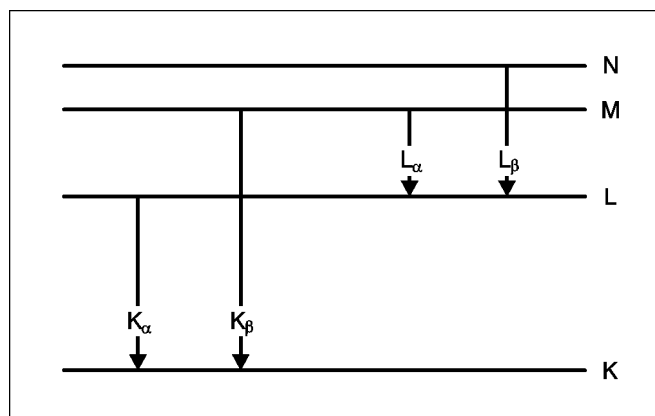

Fig. 1: Simplified terminology diagram of an atom demonstrating the characteristic x-ray lines.

In addition to the *primary* excitation by the electrons in the x-ray tube, the characteristic lines can also be excited through the irradiation of a target with high energy photons. Here the ionisation of the target atom is caused through the absorption of an x-ray photon. This process of *secondary* excitation is also called *x-ray fluorescence*.

In order to calculate the energies corresponding to the characteristic lines, the energy levels in the atom (binding energies in the electron shells) have to be known. These can be treated in a similar way to hydrogen by replacing the real charge of the nucleus Z by the effective charge $Z_{\text{eff}} = Z - \sigma_n$ with an atomic screening constant σ_n .

Apparatus

1 set of x-ray apparatus with Mo x-ray tube and goniometer or	554 811
1 set of x-ray apparatus with Cu x-ray tube and goniometer	
1 x-ray energy detector	559 938
1 k-lines fluorescence target set	554 844
1 CASSY sensor	524 010
1 MCAbox	524 058
1 CASSY Lab	524 200
1 HF cable, 1 m	501 02
1 PC with Windows 98/NT or higher	

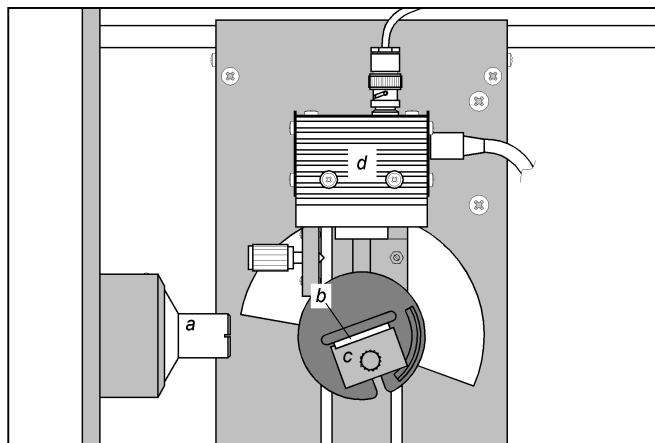

Fig. 2: Experimental setup: a – collimator, b – target, c – target table, d – detector.

The energy of an electron in an inner shell is then approximately represented by a modified Bohr's formula with the principal quantum number n and $Z - \sigma_n$:

$$E_n = -Rhc \frac{(Z - \sigma_n)^2}{n^2},$$

with R being the Rydberg constant, $R = m_e e^4 / 8 \epsilon_0^2 h^3 c$. The principal quantum number n refers to the electron shells: $n = 1$ for the K -shell, $n = 2$ for the L -shell, $n = 3$ for the M -shell etc. This formula describes the energy structure of an electron in an inner shell. The atomic screening constant σ_n in general depends on n and Z .

For the frequencies of the characteristic lines $\nu = (E_2 - E_1)/h$ with the transitions $n_2 \rightarrow n_1$ ($n_2 > n_1$) the following applies:

$$\nu = cR \left[\frac{(Z - \sigma_{n1})^2}{n_1^2} - \frac{(Z - \sigma_{n2})^2}{n_2^2} \right].$$

If instead of σ_{n1} and σ_{n2} a single average atomic screening constant $\sigma_{2,1}$ is introduced for the transitions from n_2 to n_1 , this formula can be re-written as *Moseley's law*:

$$\sqrt{\frac{\nu}{\nu_R}} = (Z - \sigma_{2,1}) \sqrt{\left(\frac{1}{n_1^2} - \frac{1}{n_2^2} \right)}, \quad (\text{I})$$

with the Rydberg frequency $\nu_R = cR$. This means that the square root of the frequency of the characteristic lines in one series is a linear function of the atomic number Z . Rewritten to get the energy of the characteristic line, equation (I) becomes:

$$\sqrt{\frac{E}{Ry}} = (Z - \sigma_{2,1}) \sqrt{\left(\frac{1}{n_1^2} - \frac{1}{n_2^2} \right)}. \quad (\text{II})$$

Here the numerical value of Ry is $Ry = Rhc \approx 2.18 \cdot 10^{-18} \text{ J} \approx 13.6 \text{ eV}$.

For the $K\alpha$ -lines of the lighter elements ($Z < 30$) the atomic screening constant is $\sigma_{2,1} \approx 1$ and therefore

$$\sqrt{\frac{E}{Ry}} = (Z - 1) \sqrt{\frac{3}{4}} \quad (\text{III}).$$

With increasing atomic number, $\sigma_{2,1}$ becomes smaller and for $Z \geq 55$ it even becomes negative, i.e. at (?) these Z the influence of the outer electrons exceeds the screening effect of the inner electrons.

Set-up

The experimental set-up is shown in fig. 2.

- Push the connection cable for the table-top device through the empty channel of the x-ray device and connect it to the mini-DIN socket of the x-ray energy detector.
- Secure the sensor holder with the mounted x-ray energy detector in the goniometer sensor arm.

This x-ray apparatus fulfils all regulations governing the construction of x-ray apparatus for use in schools and fully protected devices for instructional use, and it is type approved for school use in Germany (NW 807 / 97 Rö).

The built-in protection and screening measures reduce the local dose rate outside the x-ray apparatus to less than $1 \mu\text{Sv/h}$, a value which is of the same order of magnitude as the natural background radiation.

■ Before commissioning the x-ray apparatus, inspect it for damage and check that the high voltage is switched off when the slide doors are opened (see the operating instructions for the x-ray apparatus).

■ Protect the x-ray apparatus from access by unauthorised people.

Overheating of the anode in the x-ray tube is to be avoided.

■ When switching on the x-ray apparatus, check if the fan in the tube chamber is rotating.

The goniometer is positioned exclusively by means of electric stepper motors.

■ Do not block the target arm and the sensor arm of the goniometer and do not use force to move them.

- Connect the signal output of the x-ray energy detector to the BNC socket SIGNAL IN of the x-ray device by means of the BNC cable included.
- Feed enough connection cable through to make complete movement of the sensor arm possible.
- Press the SENSOR button and set the sensor angle with the twist adjuster ADJUST manually to 90°.
- Connect sensor CASSY to the computer and connect the MCA box.
- Connect the SIGNAL OUT output in the connection panel of the x-ray device to the MCA-box by means of the BNC cable.
- Set the distances between the slit aperture of the collimator and the axis of rotation as well as between the axis of rotation and the window of the x-ray energy detector both to 5 to 6 cm.
- Place the titanium (Ti) target from the K-line fluorescence target set onto the target table.
- Press the TARGET button and adjust the target angle manually using the twist button ADJUST to 45°.

Carrying out the experiment

- Connect the table-top power supply to the mains (after approx. 2 min the LED of the x-ray energy detector will glow green and the device will be ready for use).
- Call CASSY Lab and set the measuring parameters "Multi-channel measurement, 512 channels, negative pulses, Gain = -2.5, Measuring Time = 180 s".
- Set the tube high voltage $U = 35$ kV, emission current $I = 1$ mA and switch the high voltage on.
- Start the spectrum recording by clicking on  or pressing F9.
- Then record spectra for the other targets in the target set for K-line fluorescence.
- Save the entire measurement under a suitable name.

Example of a measurement

From the example of a measurement (fig. 3a-h), it is apparent that the energy of the characteristic lines and the separation between the α -component and the β -component of the K-spectrum series increases with increasing atomic number.

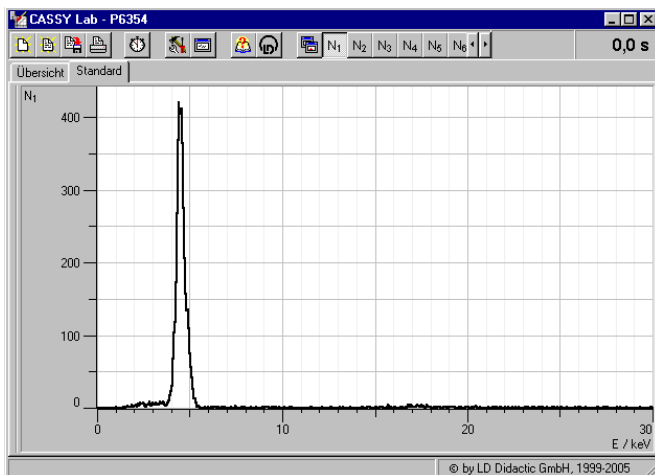

Fig. 3a: X-ray fluorescence spectrum of titanium (Ti).

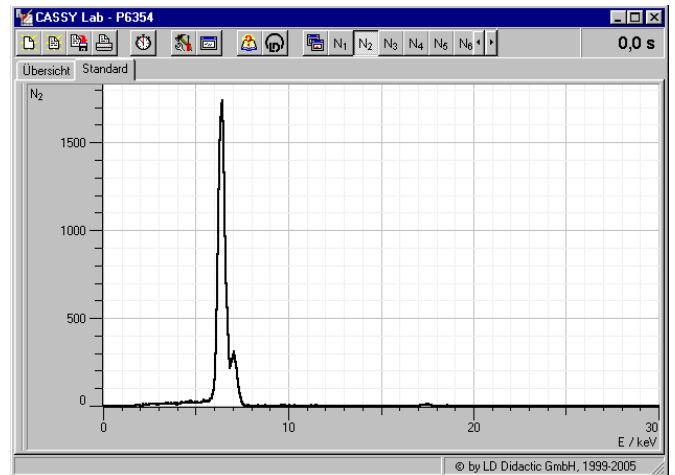

Fig. 3b: X-ray fluorescence spectrum of iron (Fe).

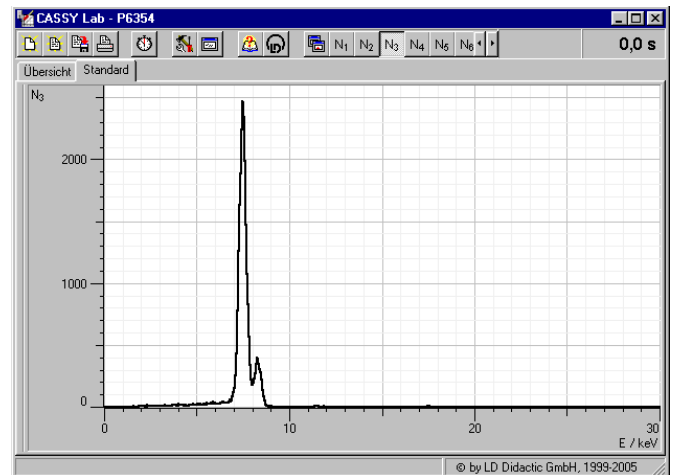

Fig. 3c: X-ray fluorescence spectrum of nickel (Ni).

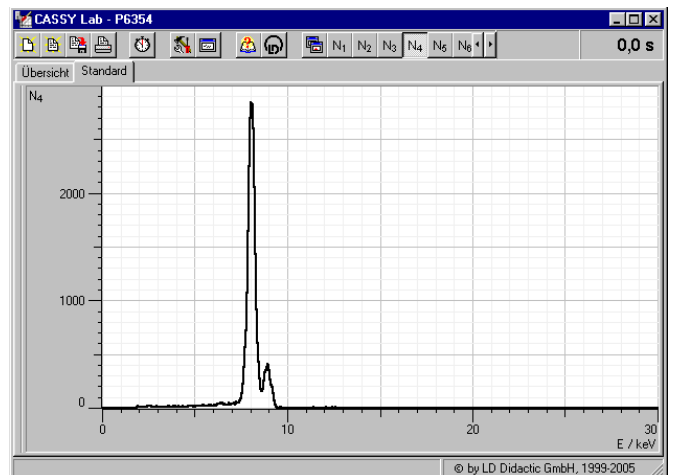

Fig. 3d: X-ray fluorescence spectrum of copper (Cu).

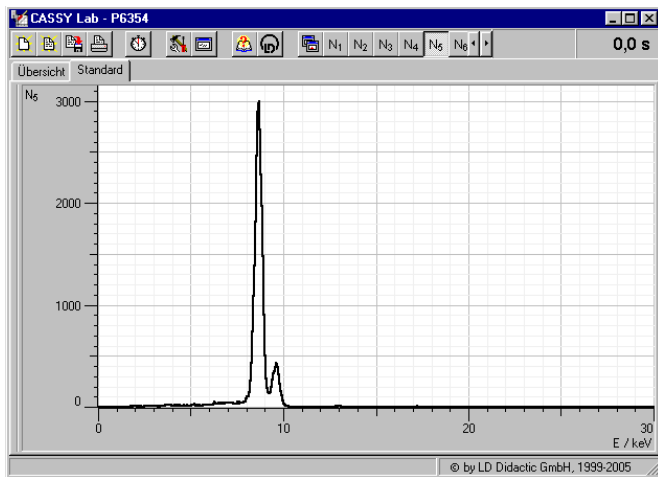

Fig. 3e: X-ray fluorescence spectrum of zinc (Zn).

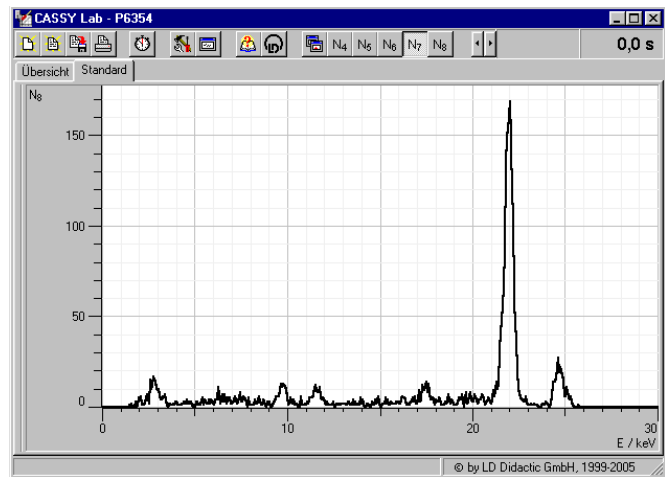

Fig. 3h: X-ray fluorescence spectrum of silver (Ag).

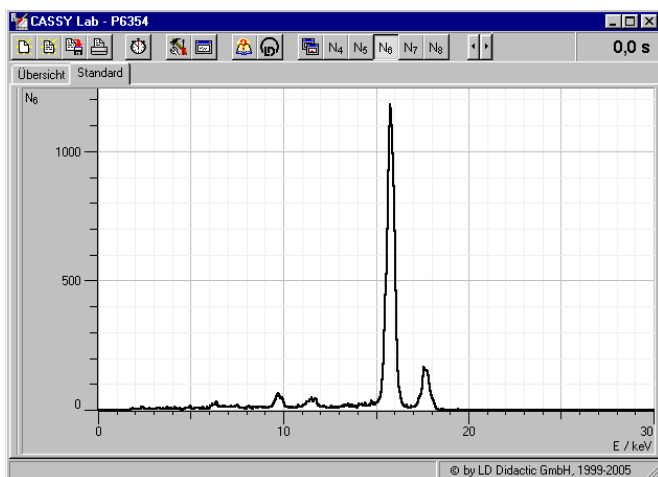

Fig. 3f: X-ray fluorescence spectrum of zirconium (Zr).

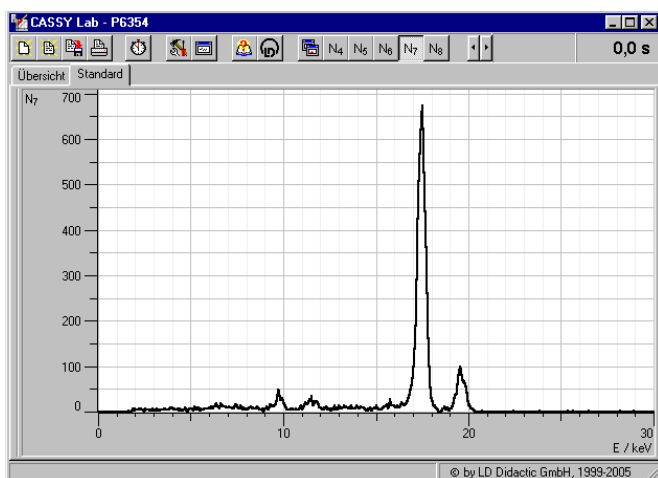

Fig. 3g: X-ray fluorescence spectrum of molybdenum (Mo).

Evaluation and results

a) Energy calibration of the spectra

The energy calibration of the spectra is made for the $K\alpha$ -lines of iron (Fe) and molybdenum (Mo).

- The spectra of iron and molybdenum are to be selected in succession.
- Open the "Energy Calibration" dialogue window by pressing Alt+E, select "Global Energy Calibration" and enter the energies for the Fe $K\alpha$ -line (6.40 keV) and the Mo $K\alpha$ -line (17.48 keV).
- In the popup menu of the diagram window select the menu item "Other Evaluations" → "Calculate Peak Center", select the Fe $K\alpha$ -line and enter the result in the "Energy Calibration" dialogue window.
- Then determine the centre for the Mo $K\alpha$ -line and enter it.

b) Proving Moseley's law and calculation of the screening constants

For the quantitative analysis, the energies of the individual lines are determined:

- Select the energy spectrum.
- In the popup menu of the diagram window call the menu item "Set Marker" → "Vertical Line" (Alt+S) and approximately mark the position of the $K\alpha$ -line and the $K\beta$ -line.
- In the popup menu of the diagram window call the menu item "Other Evaluations" → "Gaussians of equal Width" and mark the area of the desired peak (also mark sufficient background!).
- Read the found peak positions from the status line and enter them into a table (see table 1).
- For every line calculate $\sqrt{E/Ry}$ and $\sigma_{i,j}$ according to equation (II) and enter them into the table ($\sigma_{i,j}$ refers to the transition from $n_2 = i$ to $n_1 = j$).

Tab. 1 Experimentally determined energies E of the K-lines and the atomic screening constants $\sigma_{i,j}$ for the corresponding electron transitions.

Element	Z	K α -line			K β -line		
		E , keV	$\sqrt{\frac{E}{Ry}}$	$\sigma_{2,1}$	E , keV	$\sqrt{\frac{E}{Ry}}$	$\sigma_{3,1}$
Ti	22	4.47	18.13	1.07	4.89	18.96	1.89
Fe	26	6.40	21.69	0.95	7.05	22.77	1.85
Ni	28	7.48	23.45	0.92	8.28	24.67	1.83
Cu	29	8.06	24.34	0.89	8.92	25.61	1.84
Zn	30	8.66	25.23	0.86	9.60	26.57	1.82
Zr	40	15.80	34.08	0.64	17.70	36.08	1.74
Mo	42	17.48	35.85	0.60	19.61	37.97	1.72
Ag	47	21.98	40.20	0.58	24.68	42.60	1.81

Other evaluations in the CASSY Lab concerning Moseley's law:

- Set up a new variable "Atomic number" (as parameter, symbol: Z, from: 0, to: 50, decimal places: 0).
- Set up a new variable "Moseley alpha" (as parameter, symbol: y_α , from: 0, to: 50, decimal places: 2).
- Set up a new variable "Moseley beta" (as parameter, symbol: y_β , from: 0, to: 50, decimal places: 2).
- Set up a new diagram called "Moseley" with the atomic number as the x-axis and y_α , y_β as the y-axis.
- Into the tables for the "Moseley" diagram enter atomic number and the values of $\sqrt{E/Ry}$ for the α -lines (as y_α) and the β -lines (as y_β) (see fig. 4).

Compare the experimentally determined values with the theoretical values calculated using equation (III):

- Select the "Moseley" diagram and use Alt+F to open the dialogue window "Free fit".
- Enter equation (III) as formula $f(x,A,B,C,D) = (x-1)*\text{sqr}(3/4)$.
- Click "Continue with Range Marking" and select a number of measuring points in the diagram.

Because the entered formula does not include any free parameters it will be displayed without any fitting. The result is a theoretical straight line calculated according to equation (III) which corresponds well to the measured values (see fig. 4).

Other evaluations in the CASSY Lab concerning atomic screening constants:

- Set up a new variable σ_α (as parameter, name: "Screening alpha", symbol σ_α , from: 0, to 3, decimal places: 2).
- Set up a new variable σ_β (as parameter, name: "Screening beta", symbol σ_β , from: 0, to 3, decimal places: 2).
- Set up a new diagram called "Screening" with the atomic number as the x-axis and σ_α , σ_β as the y-axis.

Into the tables for the "Screening" diagram enter atomic

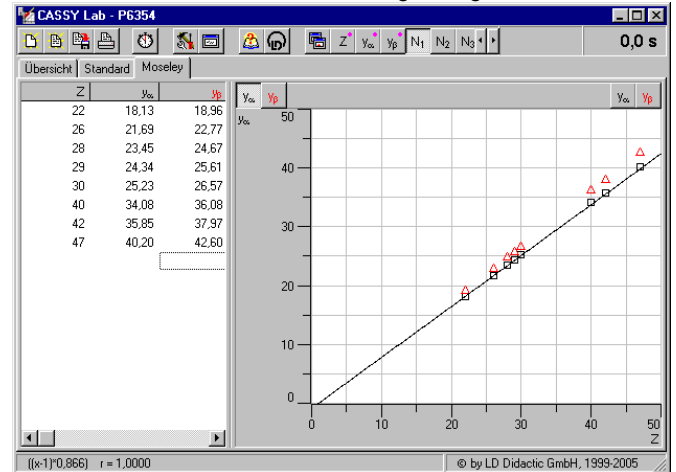

Fig. 4 Graphical representation of Moseley's law. Experimental values of $\sqrt{E/Ry}$ for the α -lines (y_α , squares) and the β -lines (as y_β , triangles) and the theoretical straight line according to equation (III).

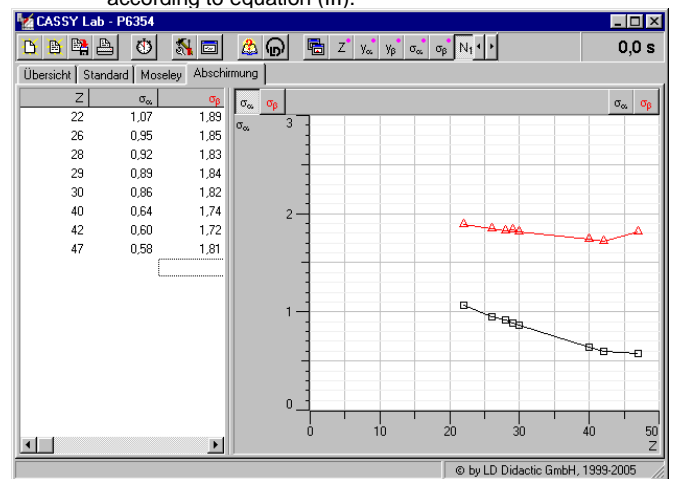

Fig. 5 Effective atomic screening constants for the electron transitions for the K-lines.

number and the values of $\sigma_{2,1}$ for the α -lines (as σ_α) and the β -lines (as σ_β) (see fig. 5).

The values $\sigma_{2,1}$ for the K α -lines determined from experimental values using equation (II) indicate that the deviation from the theoretically expected $\sigma=1$ increases with increasing atomic number Z. This is explained by the fact that the influence of the external electrons increases as the number of electrons increases.

The screening constants $\sigma_{3,1}$ for the K β -lines have a value ≈ 2 which indicates as expected a stronger effective screening of the nucleus charge for the electron transitions from the higher level $n_2 = 3$.

