

Investigating the Hall effect in silver

Objects of the experiment

- Validation of the proportionality of the Hall voltage and the magnetic flux density.
- Determining the polarity of the charge carriers.
- Calculating the Hall constant R_H and the charge carrier concentration n .

Principles

If a current-carrying metallic conductor strip is located in a magnetic field B perpendicular to the direction of the current I , a transverse electrical field E_H and a potential difference is produced (Hall effect).

The following equation holds for the Hall voltage U_H (Fig. 1):

$$U_H = \frac{1}{n \cdot e} \frac{B \cdot I}{d} \quad (I)$$

B : magnetic flux density

I : current through the metallic conductor

d : thickness of the band-shaped conductor

n : concentration of charge carriers

$e = 1.602 \cdot 10^{-19}$ C: elementary charge

The Hall voltage U_H is caused by the deflection of the moving charge carriers in the magnetic field due to the Lorentz force, whose direction may be predicted by the right hand rule. The

factor $\frac{1}{n \cdot e}$ is called Hall constant R_H :

$$R_H = \frac{1}{n \cdot e} \quad (II)$$

The sign of the Hall constant R_H is determined by the polarity of the charge carriers.

The Hall constant depends on the material and the temperature. For metals R_H is very small, however, for semiconductors R_H becomes significantly large (compare experiments P7.2.1.3 and P7.2.1.4).

The polarity of the charge carriers can be determined from the direction of the Hall voltage. The concentration of the charge carriers n can be determined experimentally by measuring the Hall voltage U_H as function of the magnetic field B for various currents I .

Fig. 1: Hall Effect schematically: Inside a charge carrying metallic conductor which is located in the magnetic field B the Lorentz force F_L is causing an electrical field E_H resulting in a Hall voltage U_H . (I denotes the transverse current).

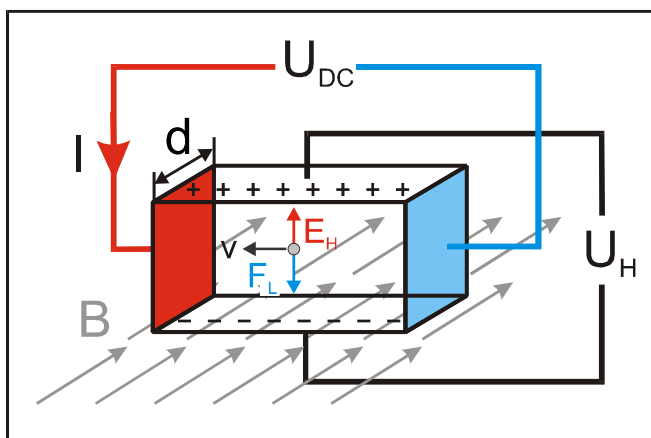

Apparatus

1 Hall effect apparatus (silver)	586 81
1 U-core with yoke	562 11
1 Pair of bored pole pieces	560 31
2 Coil with 250 turns	562 13
1 High current power supply	521 55
1 Variable extra low-voltage transformer	521 39
1 Multimeter LD analog 30	531 130
4 Pair cables 100 cm, red/blue	501 46
2 Connecting lead 100 cm black	501 33
1 Leybold multiclamp	301 01
1 Stand rod, 25 cm	300 41
1 Stand base, V-shape, 20 cm	300 02

Option (a)

1 Microvoltmeter	532 13
1 Universal Measuring Instrument Physics	531 835
1 Combi B-Sensor S	524 0381
1 Extension cable, 15-pole	501 11

Option (b)

2 Mobile-CASSY	524 009
1 μ V-Box	524 040
1 Combi B-Sensor S	524 0381
1 Extension cable, 15-pole	501 11

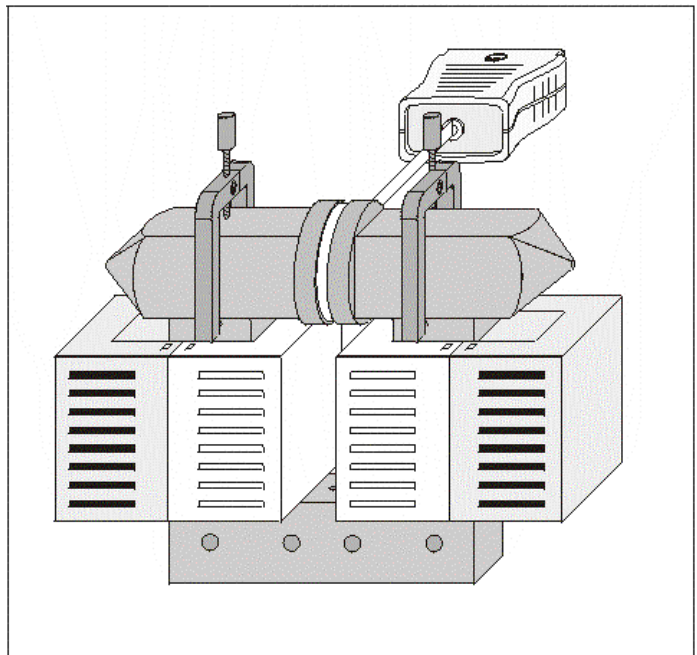

Fig. 2: Calibration of the magnetic field schematically

b) Measuring the Hall voltage as function of the magnetic field

After recording the calibration curve mount the Hall effect apparatus in the electromagnet. The pole pieces have to be pushed as close as possible to the support plate (i.e. the air gap between the pole pieces as narrow as possible and of the same width as for recording the calibration curve).

Safety notes

- For transverse currents over 15 A or magnet currents above 5 A, only switch on the device briefly (overheating of leads or overloading of the coils, which are designed for a maximum load of 5 A).
- In the transverse current circuit, use cables which are rated for a maximum load of 20 A (e.g. connecting leads 501 20 ff or safety connecting leads 500 610).
- Protect the experiment setup from drafts while measuring the Hall voltage.

Setup

The experiment is performed in two steps:

a) Calibration of the magnetic field

Set up the U-core with yoke, the pair of bored pole pieces and the coil with 250 turns as shown in Fig 2. Set the pole piece spacing of the electromagnet exactly to the thickness of the support plate of the Hall effect apparatus. To do this loosen the clamping devices and place one edge of the Hall effect apparatus between the pole pieces. Then push the latter as close as possible to the pole pieces.

Connect the coils with 250 turns in series to the extra low-voltage transformer and locate the Combi B-Sensor S between the pole pieces.

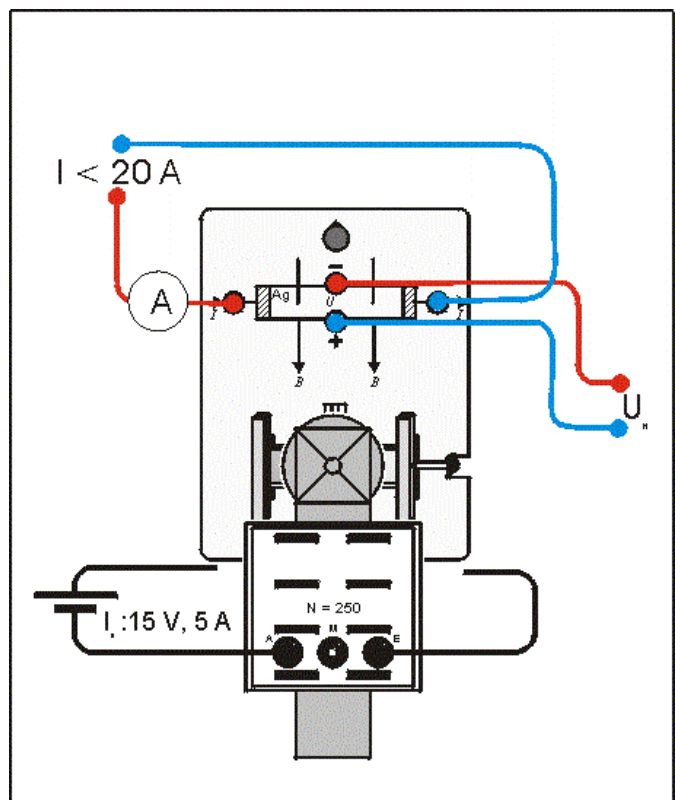

Fig. 3: Experimental setup (wiring diagram) for the Hall effect.

To measure the Hall voltage connect either the Micro-voltmeter or the Mobile CASSY with the μV -Box to the support plate of the Hall effect apparatus.

Connect the Hall effect apparatus to the high current power supply as shown in Fig. 3. The B-field direction should be as printed on the support plate. For measuring the current I through the coils the Multimeter LD analog 30 is used.

Carrying out the experiment

Note: For further notes to the experiment see also instruction sheet 586 81/84.

a) Calibration of the magnetic field

- Demagnetize the iron of the electromagnets before recording the magnetic field as function of the current I by allowing to flow a $I = 5$ A AC current through the field coils 250 turns for a short time; then steadily reduce the current to zero.
- To measure the current I through the coils connect the ammeter between the positive pole of the voltage transformer and the coil.
- Measure the magnetic flux density B as function of the current I by increasing the current I in steps of 0.5 A DC.

b) Measuring the Hall voltage as function of the magnetic field

- Mounting the Hall effect apparatus between the pole pieces (Fig. 3.).
- Before exposing the Hall effect apparatus to the magnetic field, adjust the zero point: Apply a transverse current I of e.g. 10 A and set the indicator of the meter for measuring the Hall voltage U_H to zero using the adjusting knob 4 (see instruction sheet 588 81/84). If the display changes after switching off, switch the transverse current back on and repeat the zero-point adjustment.
- Apply a transverse current $I = 15$ A to the Hall effect apparatus and measure the Hall voltage U_H as function of magnetic field B (Read off the effective field value from the calibration curve of part a)). Carry out several measurements to determine a mean value for the Hall voltage U_H . For further measurement hints see also the instruction sheets 568 81/84 (Hall effect apparatus) and 532 13 (Microvoltmeter).
- Repeat the measurement for a transverse current $I = 20$ A.

Measuring example

a) Calibration of the magnetic field

Table. 1: Magnetic field B as function of the current I through the coils.

$\frac{I}{\text{A}}$	$\frac{B}{\text{T}}$
0.0	0.000
0.5	0.118
1.0	0.200
1.5	0.295
2.0	0.374
2.5	0.455
3.0	0.520
3.5	0.585
4.0	0.630
4.5	0.665
5.0	0.695
5.5	0.715
6.0	0.735
6.5	0.748
7.0	0.760
7.5	0.780
8.0	0.790
8.5	0.800
9.0	0.810

The data of table 1 are plotted in Fig. 4.

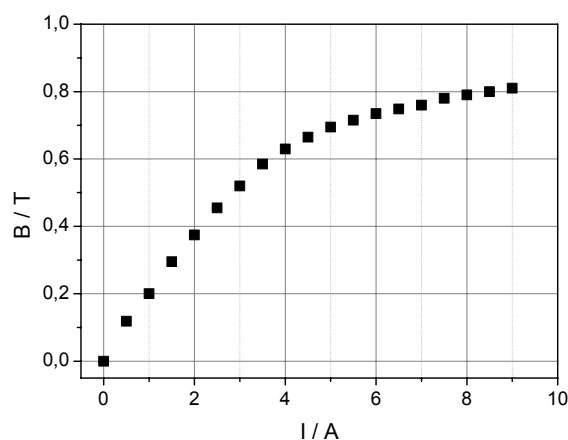

Fig. 4: Calibration curve magnetic field as function of current I .

b) Measuring the Hall voltage as function of the magnetic field

Table. 2: Hall voltage U_H (absolute value) as function of the magnetic field B for constant transverse currents I .

$\frac{B}{T}$	$\frac{U_H}{\mu V}$ ($I = 15 \text{ A}$)	$\frac{B}{T}$	$\frac{U_H}{\mu V}$ ($I = 20 \text{ A}$)
0.20	4.6	0.20	6.25
0.35	8.2	0.38	11.7
0.51	12.0	0.50	15.0
0.62	14.1	0.61	18.1
0.70	16.1	0.68	20.5
0.73	17.0	0.70	21.0
0.76	17.7	0.72	21.6
0.78	18.1	0.76	22.7
0.80	18.6	0.80	24.0

The polarity of the Hall voltage U_H was determined to be negative.

Results

b) Measuring the Hall voltage as function of the magnetic field

The recorded data of Table 2 for the transverse currents $I = 15 \text{ A}$ and $I = 20 \text{ A}$ are plotted in Fig. 5.

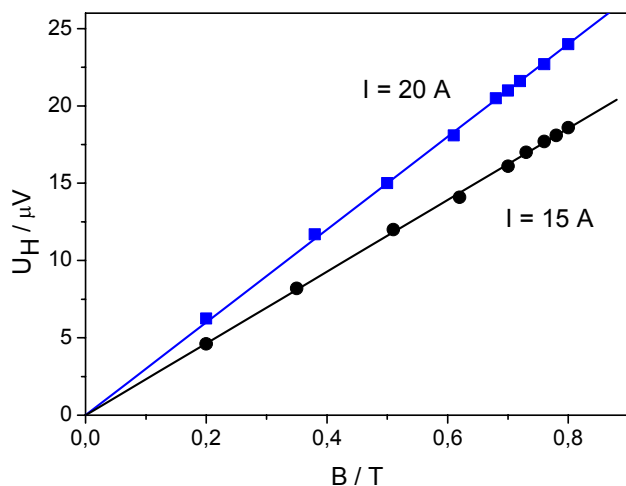

Fig. 5: Hall voltage U_H as function of the magnetic field B for currents $I = 15 \text{ A}$ (circles) and $I = 20 \text{ A}$ (squares). The solid lines correspond to a fit of equation (I).

Evaluation

Form Fig. 5 follows that the Hall voltage U_H is proportional to the magnetic field B :

$$U_H \sim B \tag{III}$$

Form Fig. 5 also follows that the Hall voltage U_H increases with increasing transverse current I :

$$U_H \sim I \tag{III}$$

Note: The proportionality between the Hall voltage U_H and transverse current I can be determined experimentally by measuring the Hall voltage U_H as function of the transverse current I for a constant magnetic field B .

From the fit of equation (I) to the experimental data is resulting the slope

$$A_H = \frac{1}{n \cdot e} \cdot \frac{I}{d}$$

$$A_H (I = 15 \text{ A}) = 23.2 \frac{\mu V}{T}$$

$$A_H (I = 20 \text{ A}) = 30.4 \frac{\mu V}{T}$$

With the thickness $d = 5 \cdot 10^{-5} \text{ m}$ the Hall constant can be determined (absolute value):

$$R_H (I = 15 \text{ A}) = 7.7 \cdot 10^{-11} \frac{\text{m}^3}{\text{C}}$$

$$R_H (I = 20 \text{ A}) = 7.6 \cdot 10^{-11} \frac{\text{m}^3}{\text{C}}$$

Literature value: $R_H = 8.9 \cdot 10^{-11} \frac{\text{m}^3}{\text{C}}$

The Hall voltage is determined to be negative. This shows that in silver the conduction mechanism is mainly effected by negative charge carriers.

With elementary charge $e = 1.602 \cdot 10^{-19} \text{ C}$ follows the concentration of charge carriers:

$$n (I = 15 \text{ A}) = 8.1 \cdot 10^{28} \frac{1}{\text{m}^3}$$

$$n (I = 20 \text{ A}) = 8.2 \cdot 10^{28} \frac{1}{\text{m}^3}$$

Literature value: $6.6 \cdot 10^{28} \frac{1}{\text{m}^3}$

(atoms density $5.8 \cdot 10^{22} \frac{1}{\text{m}^3}$)

Supplementary information

In 1916, Tolman obtained certain proof that electrons are the charge carriers in metals.