

## He-Ne Laser, Linear Polarized

The He-Ne laser produces a narrow, (almost) parallel beam of monochromatic, coherent, linear polarized light.

### Areas of application:

- Geometrical optics (path of the rays when reflected and refracted)
- Wave optics (diffraction, interference, interferometry)
- Holography (producing and reconstructing of holograms)
- Faraday effect, Kerr effect, saccharimetry

## 1 Safety Notes



Read the Instruction Sheet!

When using the unit properly according to the information given in the Instruction Sheet, experimenting with the He-Ne-Laser is not dangerous!

This laser meets the requirements laid down in DIN 58 126, Part 6, for lasers of class 2 which are used for teaching purposes:

- Optical output power 0.2 mW which can be increased to 1 mW when operating a switch.
- Protection against misuse by built-in key switch.
- Riveted housing for protection against opening.

These safety measures ensure safe operation when handling the instrument correctly.

- Keep key ② in a safe place.
- Never look directly into the direct or reflected laser beam!
- Observe safety notes given in chapter 3.2.

A suitably qualified person must be nominated in schools where experiments are carried out with lasers. This person is responsible for the proper use of lasers and the necessary safety precautions.

This refers to the Federal Republic of Germany and is laid down by DIN. In other countries different laws may apply and enquiries should be directed to the appropriate authorities.

## 2. Scope of supply, description

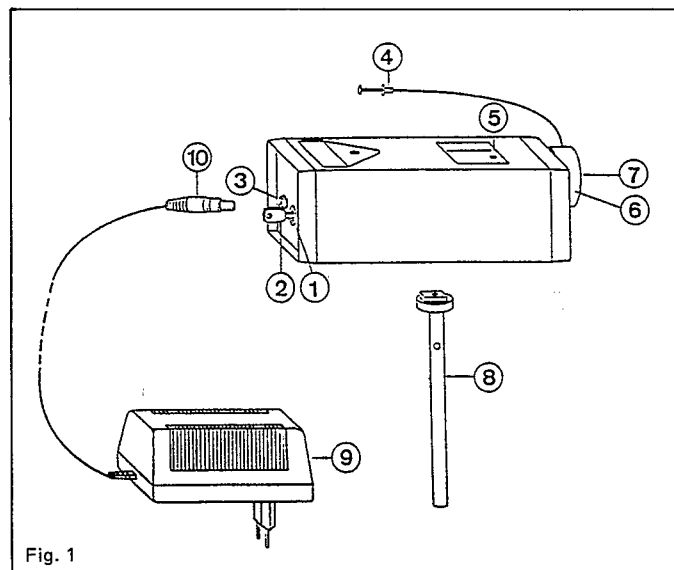

Fig. 1

- ①, ② Key-operated switch with key for switching laser beam on and off
- ③ Connection socket for plug-in power supply unit
- ④ Wire trip, with which a grey filter (in ⑥) is slewed out of the path of light to raise the output power to 1 mW
- ⑤ Power-on indicator lamp
- ⑥ Filter holder with grey filter for limiting the output power to 0.2 mW; filter can be slewed out of the path of light using wire trip ④
- ⑦ Beam aperture
- ⑧ Stand rod (approx. 13 cm long, 10 mm dia.) for mounting unit to stand material, e.g. stand base (300 01) or multi-clamp (301 01) on small optical bench (460 43). Laser may be moved along beam axis.
- ⑨ Plug-in power supply
- ⑩ Connecting plug for socket ③

#### Technical data:

He-Ne laser	
Optical output power:	0.2 mW, switchable to 1 mW (max.)
Beam diameter:	0.48 mm
Beam divergence:	1.7 mrad
Wavelength:	632.8 nm
Mode:	TEM <sub>00</sub>
Polarization:	linear, 500:1
Life-span of the laser tube:	>15,000 hours
Connection voltage:	12 V d.c.
Weight:	0.7 kg
Dimensions:	20 cm x 6 cm x 5 cm
Plug-in power supply for the He-Ne laser:	
Primary:	220 V a.c., 50/60 Hz
Secondary:	12 V d.c.

### 3 Operation

*Note:* When preparing and carrying out experiments, observe the information given in chapter 3.2.

#### 3.1 Switching the laser on and off

*Switching the laser on and off at an optical output power of 0.2 W (normal operation):*

In order to switch the laser on, turn key operated switch ① with key ② by 90° in the clockwise direction so that the white marking notch corresponds to the plane of the key.

Correct operation is indicated by lamp ⑤.

The laser beam will either appear immediately, or (if the laser hasn't been used for quite a while) some seconds later at the beam output opening.

To switch the laser off, turn the key-operated switch by 90° in the counterclockwise direction.

*Switching to 1 mW:*

By pressing wire release ④ the grey filter (in ⑦) is removed from the path of the beam.

The wire release should be held slightly upwards so that no mechanical forces are transferred to the laser housing. When the wire release is not depressed, the output power is limited to 0.2 mW – normal operation.

#### 3.2 Regulations and recommendations for safe experimenting with lasers (class 2).

According to DIN 58 126, part 6 (lasers of class 2 used in teaching):

"All experiments with lasers should be carried out with the lowest possible optical output power. When observing patterns in either diffuse, scattered or defracted laser light, the threshold line of glare should never be exceeded.

When experiments are assembled, only persons who are suitably informed about the dangers of laser light may take part during preparation. Also persons who take part in observing laser experiments must be informed about the dangers of laser light, especially about the dangers of directly looking into a laser beam.

The area in which the laser is used should be blocked (rope, barrier etc.) to prevent from inadvertently entering the area.

Rooms where lasers are used must be equipped with suitable laser warning signs".

The laser should be arranged in such a way that only a small and not easily accessible area is covered by the laser beam and uncontrolled reflections, e. g. from a window, must be avoided.

Limiting the laser beam to the space provided on a lab table is highly desirable.

The laser and any objects placed in the beam of the laser light should be mounted in such a way that inadvertent changing of their position is avoided.

This can be best done by mounting the laser and the optical accessories onto an optical bench.

The beam of laser light should be limited by using either a translucent screen or some other non-reflecting material.