

Physics

Chemistry · Biology

Technology



Leybold Didactic GmbH
Lehr- und Didaktiksysteme

06/04-W97-Kern

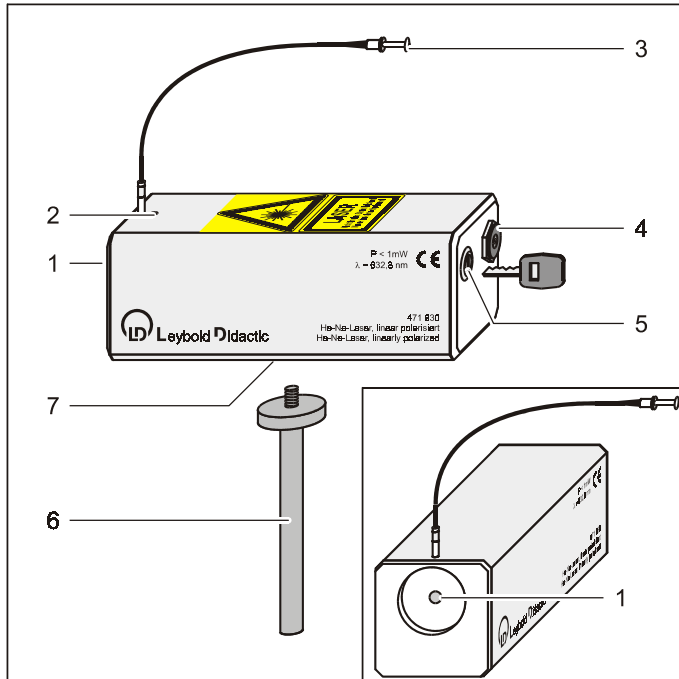

Instruction sheet 471 830

He-Ne laser, linearly polarised (471 830)

- 1 Beam aperture, with grey filter
- 2 Power-on indicator
- 3 Wire trip
- 4 Input socket for plug-in power supply
- 5 Key switch
- 6 Stand rod with thread
- 7 Threaded bush

1 Description

The He-Ne laser provides a narrow, almost parallel bundle of monochromatic, coherent and linearly polarised light.

Safety notes

The He-Ne laser emits visible radiation with a wavelength of 632.8 nm at a maximum optical output power below 1 mW, thus meeting the requirements according to class 2 of EN 60825-1 "Safety of laser equipment". That means protection of the human eye usually depends on averting reactions including the lid closure reflex.

Moreover, the He-Ne laser can only be put into operation by means of a key switch, maximum optical output power is only obtained by operating a wire trip, and the on-state is always seen thanks to a conspicuous power-on indicator.

Nevertheless the following safety notes have to be heeded:

- Never look directly into the laser beam.
- Allow only authorized and instructed persons to operate the He-Ne laser.
- Inform all persons who participate in the experiment and in the observations about the dangers of laser light and about necessary protective measures.
- When carrying out experiments, do not exceed the minimum required optical output power in each case.
- Align the ray path so that it does not run at eye level.

- Restrict the area covered by the laser by means of screens, and avoid unintended reflections.
- Rooms where experiments with laser light are carried out have to be equipped with warning signs.
- In Germany, the regulations for prevention of accidents BGV B2 "Laser Radiation" and, if existing, decrees of the ministers of education and cultural affairs have to be observed. In other countries, corresponding regulations have to be observed.

If the He-Ne laser is used as prescribed, its safe operation is guaranteed. However, safety is not guaranteed if the He-Ne laser is improperly used or carelessly handled. If it has to be assumed that safe operation is no longer possible, the He-Ne laser has to be shut down immediately (e.g. in the case of visible damage).

- Before putting the laser into operation, examine the housing for damage. In case of malfunction or visible damage shut the He-Ne laser down and make sure that it is not used inadvertently.
- Under no circumstances open the housing. The operation and ignition voltage in the interior may be dangerous to life.

2 Scope of supply

1 He-Ne laser
 2 keys
 1 stand rod
 1 wire trip
 2 warning signs
 1 plug-in power supply 230 V / 12 V AC (562 791)
 or
 1 plug-in power supply 115 V / 12 V AC (562 792)

3 Technical data

Wavelength:	632.8 nm
Optical output power with grey filter	< 1 mW < 0.2 mW
without grey filter	> 0.5 mW
Beam diameter:	0.48 mm
Beam divergence:	1.7 mrad
Mode:	TEM ₀₀
Minimum polarisation:	500 : 1
Life of tube:	> 18,000 h
Input voltage:	12 V AC, 20 W
Dimensions:	6 cm × 6 cm × 17 cm
Stand rod:	11 cm × 10 mm dia.
Weight:	850 g

4 Operation

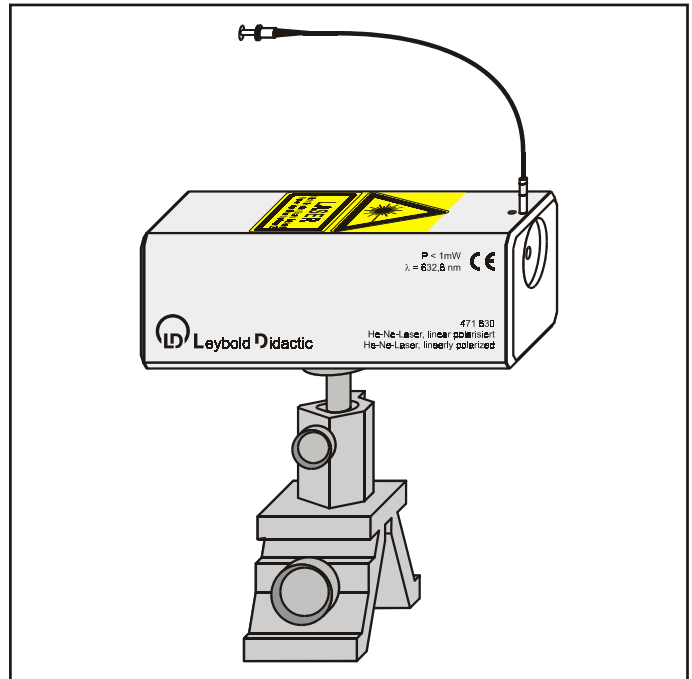

- The stand rod being screwed in, attach the He-Ne laser to an optical bench with the aid of an optics rider

or for use on the laser optics base plate (473 40):

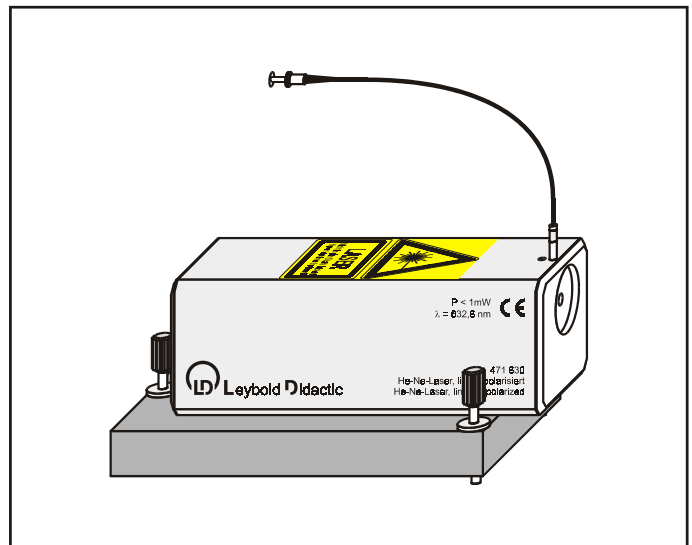

- Mount the He-Ne laser on the laser mount (473 411).
- Operate the key switch for switching the laser on.
- If desired, take the grey filter out of the ray path by pressing the wire trip in order to obtain a higher optical output power.